

Eight equivalent circuits for the FTFN \pm in PSPICE simulator

CHUN-LI HOU, CHEN-CHUAN HUANG AND CHEN-KUM CHANG

*Department of Electronic Engineering
Chung Yuan Christian University
Chung-Li, 32023, Taiwan, R.O.C.*

CHUN-MING CHANG

*Department of Electrical Engineering
Chung Yuan Christian University
Chung-Li, 320, Taiwan, R.O.C.*

(Received: May 11, 2000 ; Accepted: August 17, 2000)

ABSTRACT

In this paper, eight new equivalent circuits for the FTFN \pm in PSPICE simulator are proposed. The new equivalent circuits for FTFN $-$ are simpler and occupy fewer memories as well as take less time than the previous published equivalent circuit. The equivalent circuits for FTFN $+$ are also proposed in this paper. The simulation results of FTFN \pm networks using the equivalent circuits are compared with the theoretical analyses.

Key words: FTFN \pm (plus and negative type four-terminal-floating nullors).

I. Introduction

Because the dependent sources and all of the generalized immittance converters (GICs) may be modeled by using RC-FTFN \pm networks, the ideas of the FTFN \pm as network elements are very important and helpful in the synthesis and analysis of active networks. Nevertheless, the FTFN \pm [1] are ideal elements, it is not easy to use digital computer for simulation. The authors give a new, simple and elegant way to explain the principle of an FTFN $-$ which is quite different from the traditional way. Four equivalent circuits of an FTFN $-$ are proposed, each contains single dependent source only. While the already available one [2] in Fig.1 which employs two dependent sources, it is apparent that the new equivalent circuits are simpler and occupy fewer memories and take less time especially for the networks containing lots of FTFN $-$. An FTFN $+$ [3], which was called OMA (Operational Mirrored Amplifier) before[4], has no simple PSPICE simulated equivalent circuit given yet. The authors propose four equivalent circuits for an FTFN $+$. A filter with OP AMPs (operational amplifiers) replaced by using the equivalent circuits of an FTFN $-$ is simulated. The simulation

results are obtained to verify the usages of the equivalent circuits.

II. Illustration

A. It is well-known that an infinite-gain controlled sources of any four types in Fig.2 is exactly equivalent to an FTFN $-$ [5]. However, the explanations are indirect and complicate. The authors try to clarify the above interpretation directly, simply and obviously.

There are four types of dependent sources:

(A) Voltage-controlled-current-source(VCCS)

In Fig.2(a), $I_1=0$, $I_2=g_m V_1$. If the value of g_m approaches infinite, the value of I_2 is finite, and $V_1=(I_2/g_m)$ is equal to zero. It is clear that for the input-port: $I_1=0$, $V_1=0$, and for the output-port: the value of V_2 (the voltage across the dependent current source) is arbitrary; and I_2 , whose value is the product of infinite g_m and zero V_1 , is arbitrary. From the above discussion, this is an FTFN $-$.

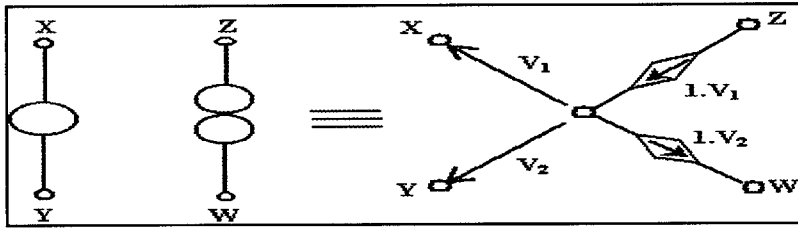

Fig.1 Equivalent circuit for the FTFN-.

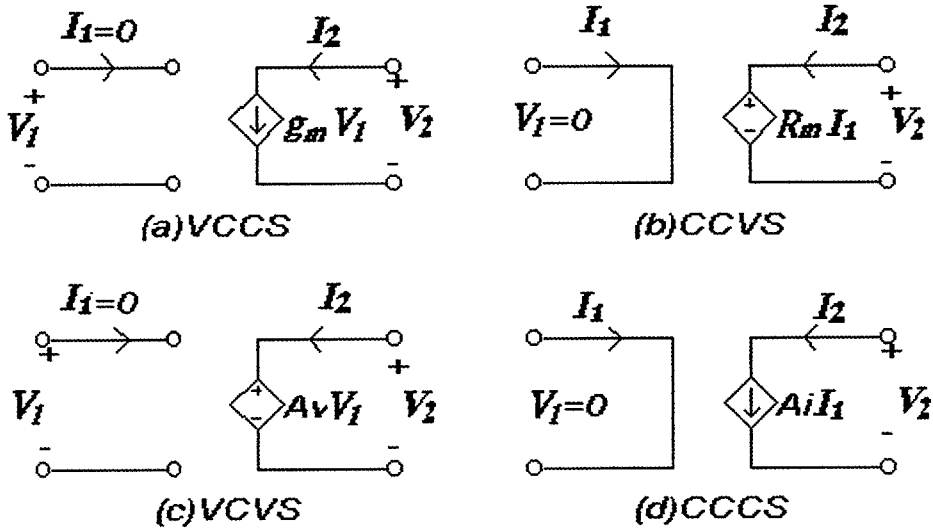

Fig.2 Four-type dependent or controlled sources.

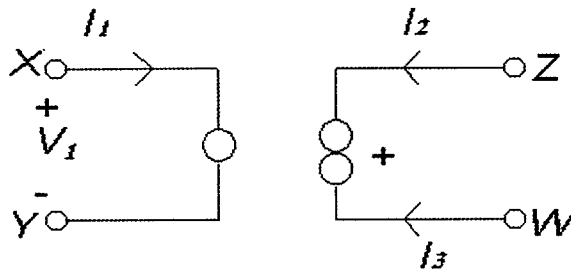

Fig.3 The FTFN+ circuit.

(B) Current-controlled-voltage-source(CCVS)

In Fig.2(b), $V_1=0$, $V_2=R_m I_1$. If the value of R_m approaches infinite, the value of V_2 is finite, and $I_1=(V_2/R_m)$ is equal to zero. It is clear that for the input-port: $I_1=0$, $V_1=0$, and for the output-port: the value of I_2 (the current through the dependent voltage source) is arbitrary; and V_2 , whose value is the product of infinite R_m and zero I_1 , is arbitrary. From the above

consideration, this is an FTFN-.

(C) Voltage-controlled-voltage-source(VCVS)

In Fig.2(c), $I_1=0$, $V_2=A_v V_1$. If the value of A_v approaches infinite, the value of V_2 is finite, and $V_1=(V_2/A_v)$ is equal to zero. It is clear that for the input-port: $I_1=0$, $V_1=0$, and for the output-port: similar to type(B), the value of I_2 , V_2 can be arbitrary. This is an FTFN-.

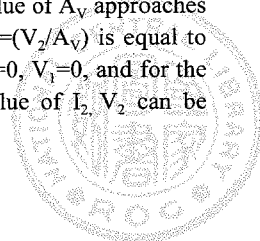

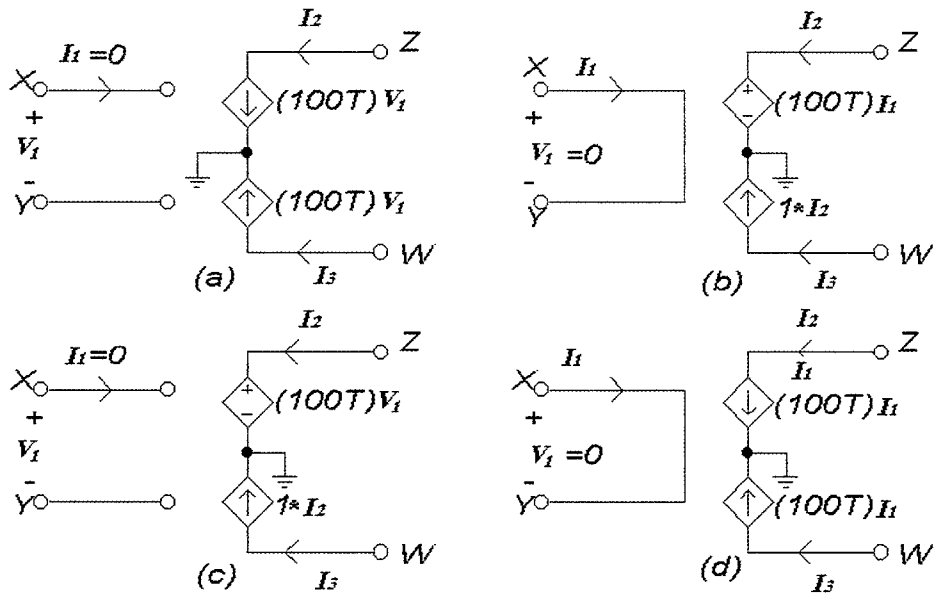

Fig.4 Simulated equivalent circuits for the FTFN+.

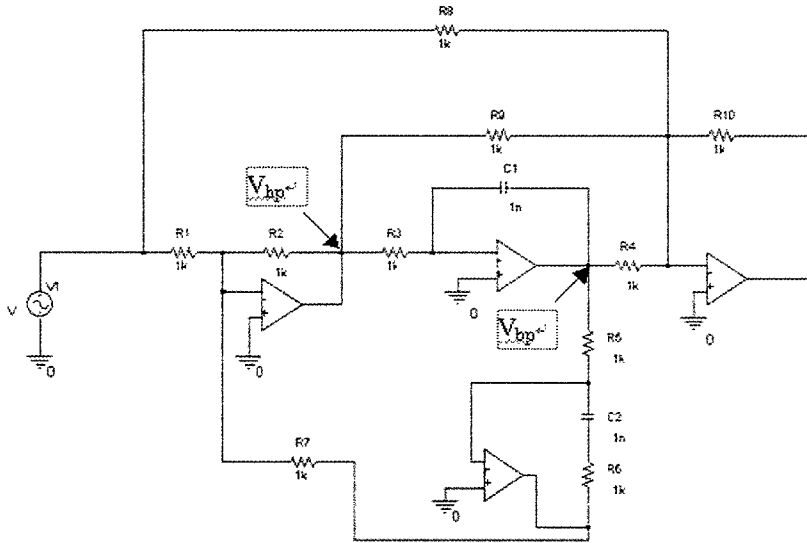

Fig.5 BHI/DF Filte

(D) Current-controlled-current-source(CCCS)

In Fig.2(d), $V_1=0$, $I_2=A_1I_1$. If the value of A_1 approaches infinite, the value of I_2 is finite, and $I_1=(I_2/A_1)$ is equal to zero. It is clear that for the input-port: $I_1=0$, $V_1=0$, and for the output-port : similar to type(A), the value of I_2 , V_2 can be arbitrary. This is an FTFN-.

In summary, all four type controlled sources in Fig.2 can become FTFN- as the values of g_m , R_m , A_v and A_1 approach infinite. Because digital computer can generate

only finite number, we may use a number large enough such that the error can be neglected. For example, we may let $g_m=100T(S)$, $R_m =100T(\Omega)$, $A_v=100T(V/V)$, $A_1=100T(A/A)$ to substitute into the corresponding source in Fig.2(where $1T=10^{12}$). These equivalent circuits can be employed in PSPICE simulator. It is obvious that only one dependent source is necessary for an FTFN- instead of the equivalent circuit of the two dependent sources in Fig.1.

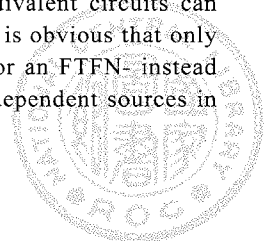

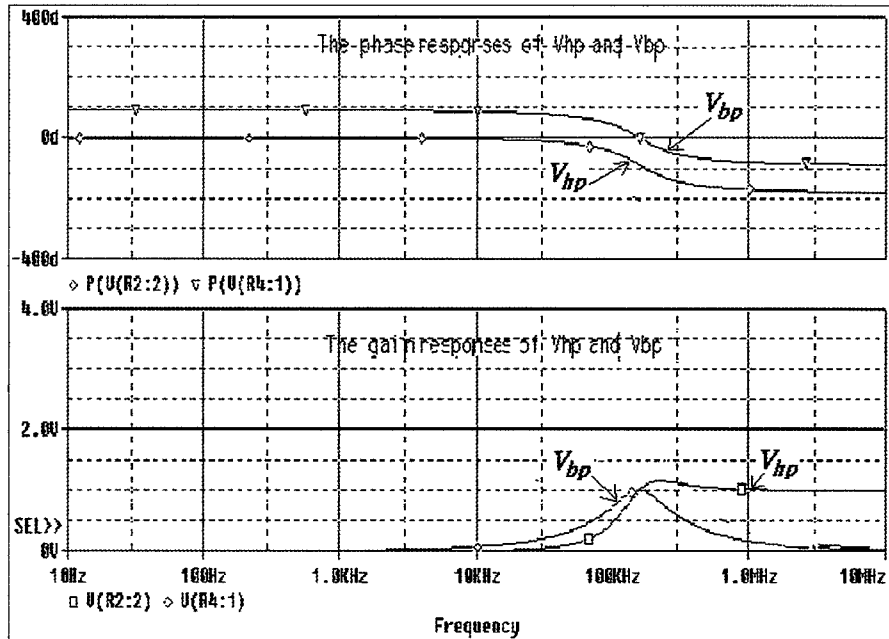

Fig. 6 The gain responses and phase responses of BHI / DF Filter in Fig.5.

B. For the FTFN+ in Fig.3, $I_1=0$, $V_1=0$, $I_2=I_3$. This is a three-port element. Four types of simulated equivalent circuits of an FTFN+ are shown in Fig.4. Note that the voltage between nodes Z and W is arbitrary.

III. Simulation results

In order to verify the equivalent circuits in the simulations of FTFN±, we want to substitute them in turns into the networks in Fig.5 .

In Fig.5, from the ideal OP AMPs (which are nullors), we take turns to employ BHI/DF filter [5] with the OP AMPs replaced by the equivalent circuits shown in Fig.2(a) (each VCCS with $g_m=100T(S)$). For ideal OP AMPs, $V(R2:2)$, $V(R4:1)$ are highpass- and bandpass- outputs by theoretical analysis. The simulation results are shown in Fig.6. It is obvious that the simulation results fit the theoretical prediction.

IV. Conclusions

The authors propose eight equivalent circuits to simulate FTFN±. In PSPICE simulator, all the equivalent circuits are alike for the digital computer. For current-controlled-sources, a voltage source with 0v should be inserted to the shorted input-port to give the flowing direction of the input current;

For voltage-controlled-source, a resistor with large resistance ($1T\Omega$ or more) have to be added to the open input-port to avoid the terminals of the input-port floating. Current-controlled-sources have a given current flowing direction at the input-port, while voltage-controlled-sources must add a resistor to have high input resistance. Therefore, current-controlled-sources are simpler than voltage-controlled-sources.

References

1. Liu, S.I., Single-resistance-controlled sinusoidal oscillator using two FTFNs, Electronics Letters, 33, 1185-1186, 1997.
2. Farchy, S., Gadzheva, E. D., Raykovska, L.H. and Kouyoumd, T.G., Nullator --Norator approach to analogue circuit diagnosis using general-purpose analysis programs, International Journal of circuit theory and applications, 23, 571-585, 1995.
3. Wang, H.Y., and Lee, C.T., Realisation of R-L and C-D immittance using single FTFN, Electronics Letters, 34, 502-503, 1998.
4. Huijsing, J.H., and Veelenure, C.J., Monolithic operational mirrored amplifier (OMA), Electronics Letters, 17, 119-120, 1981.
5. Bruton, L. T., RC-Active Circuits: Theory and Design (Prentice-Hall), 1980.

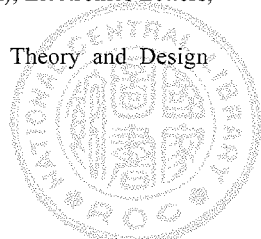

可用 PSPICE 模擬的正負型四端點浮接式
nullor 的八種等效電路

侯俊禮 黃振權 張振昆

中原大學電子系
台灣省中壢市普仁 22 號

張 俊 明

中原大學電機系
台灣省中壢市普仁 22 號

摘 要

本論文提出可用 PSpice 模擬 FTFN \pm (正負型四端點浮接式 nullors) 的八種等效電路。而此新的負型 FTFN 等效電路，較先前已發表之等效電路為簡單、不佔記憶體空間且不費時。同時也會提出正型 FTFN 等效電路。並提出一個由 FTFN \pm 所組成的網路，將其模擬結果與理論分析做比較。

關鍵詞：FTFN \pm 正負型四端點浮接式 nullor。

